

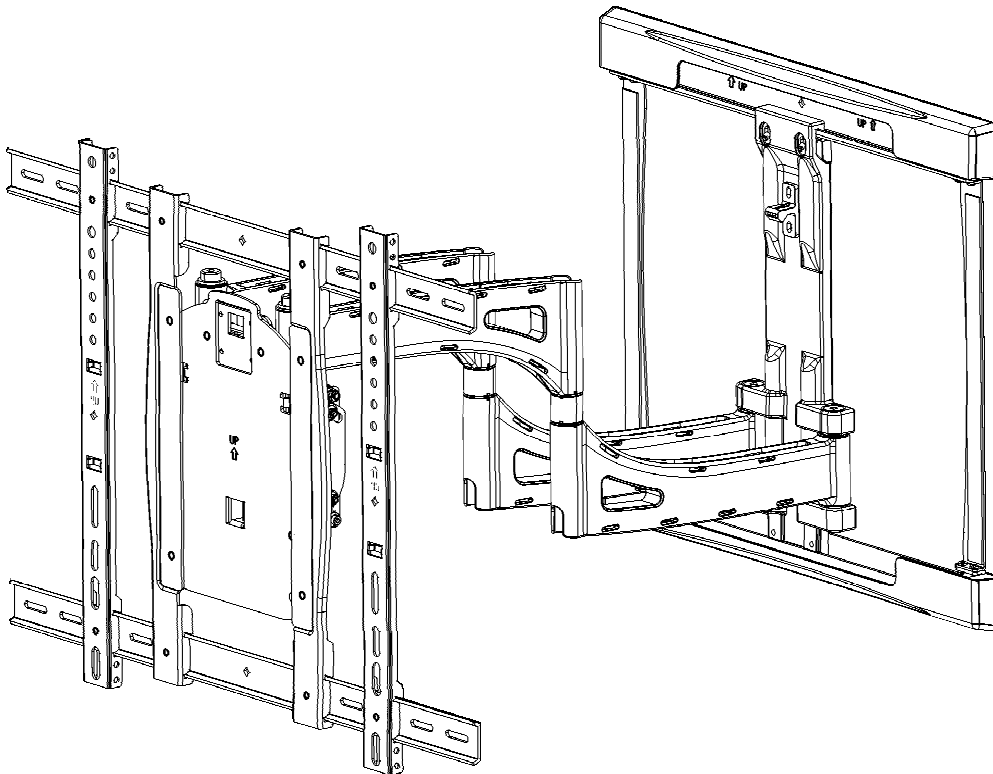

SM-RAZOR-ART2-L / SM-RAZOR-ART2-XL

**Strong™ Razor Series
Articulating Mount for Large and Extra Large Displays**



INSTALLATION MANUAL

Warnings:

- Installation of this product should be done by a qualified professional.
- Do not begin installation before reviewing and understanding these instructions.
- Ensure the mounting wall used can safely support 4 times the combined weight of the mount and chosen display.
- The manufacturer does not accept responsibility for incorrect installation.



CAUTION: This wall mount is intended for use only with the maximum weight of 100lbs/45.35 kg. Use with heavier than the maximum weight indicated may result in instability causing possible injury.



Specifications:

Maximum Load:

SM-RAZOR-ART2-L	100 lbs.
SM-RAZOR-ART2-XL	100 lbs.

VESA Patterns:

SM-RAZOR-ART2-L:	Up to VESA 600mm x 400mm
SM-RAZOR-ART2-XL:	Up to VESA 800mm x 600mm
Note: Max VESA 800x600 requires use of (AF) Extension Brackets.	

Tools Required:

- Power Drill
- 1/4" Drill Bit
- Phillips Head Screw Driver
- Level
- 1/2" (13mm) Socket Wrench
- Stud Finder
- Zip Ties (For Wire Management)
- 5/16" Drill Bit (Concrete Mounting Only)
- Hammer (Concrete Mounting Only)

Package Contents

Mount & Accessories

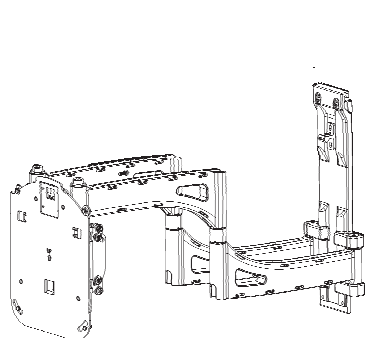

Wall Arm Assembly
(x1)

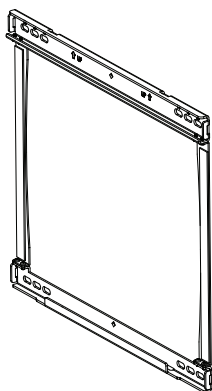

Wall Bracket (x1)

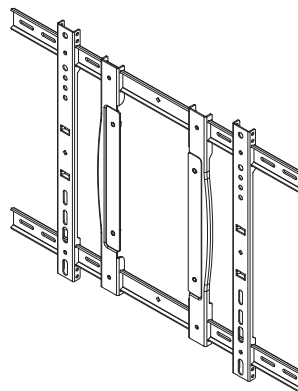

TV Plate (x1)

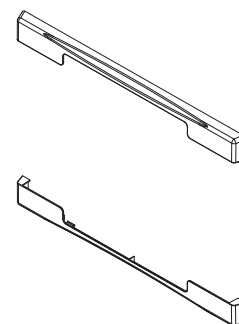

Wall Bracket End
Covers
(x2)

Hardware

Bag 1



(A) Black, Philips drive machine screw, M4x10 (4)



(B) Black, Philips drive machine screw, M4x20 (4)



(C) Black, Philips drive machine screw, M4x30 (4)



(D) Black, Philips drive machine screw, M4x40 (4)



(E) Black, Philips drive machine screw, M5x10 (4)



(F) Black, Philips drive machine screw, M5x20 (4)



(G) Black, Philips drive machine screw, M5x30 (4)



(H) Black, Philips drive machine screw, M5x40 (4)



(I) Black, Philips drive machine screw, M6x10 (4)

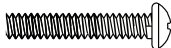

(J) Black, Philips drive machine screw, M6x20 (4)



(K) Black, Philips drive machine screw, M6x30 (4)



(L) Black, Philips drive machine screw, M6x40 (4)

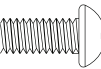

(M) Black, Philips drive machine screw, M8x10 (4)

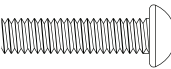

(N) Black, Philips drive machine screw, M8x20 (4)

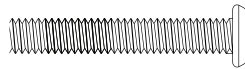

(O) Black, Philips drive machine screw, M8x30 (4)

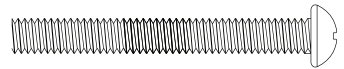

(P) Black, Philips drive machine screw, M8x40 (4)



(Q) OD12xID5.5x5 Black Nylon Spacer (8)



(R) OD15xID8.5x5 Black Nylon Spacer (8)



(S) Black, M5 washer, M5x12x1 (16)



(T) Black, M8 washer, M8x19x2 (8)

Bag 2



(U) M8x90 Lag Bolt (4)



(V) Washer 9.5x21x2 (4)

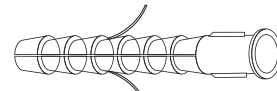

(W) Concrete Anchors 10x80 (4)

Bag 3



(X) Washer, M6, 6.5*18*2 (2)



(Y) Black, M6 Lock nuts (2)

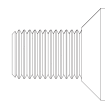

(Z) Black, M6x12 Counter Sunk Hex Head Screw (2)

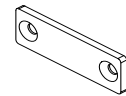

(AA) Bottom Mounting Block (1)

Bag 4



(AB) S4 Allen Key (1)

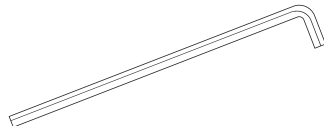

(AC) S5 Allen Key (1)

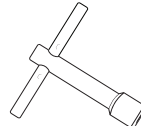

(AD) S10 Socket Wrench (1)

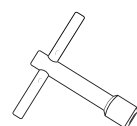

(AE) S8 Socket Wrench (1)

Bag 5

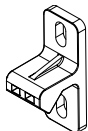

(AH) Latching Clip (1)

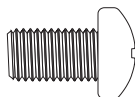

(AI) M5x8 bolts (2)

Bag 6 (XL Only)

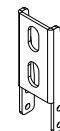

(AF) Extension brackets (4)

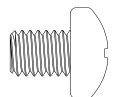

(AG) machine screw, M5x6 (16)

Installation

Step 1. Pre-Drill Wall for Mounting

A. For Mounting on a Stud Wall

- A-1. Place the Wall Plate on the wall in the desired position for the display.
- A-2. Mark the mounting hole locations over the wall studs.
- A-3. Drill 4 holes into two wood studs using a 1/4" drill bit. Be sure to drill into the center of the studs at least 3-1/2" deep. The use of a stud finder is highly recommended.

B. For Mounting on a Concrete Wall

- **WARNING: When installing wall bracket on cinder block: Verify first that you have a minimum of 1-3/8" of concrete thickness to be used for the concrete anchors.**
- Do not drill into mortar joints! Be sure to mount in a solid part of the block, generally 1" minimum from the side of the block.
- Cinder block must meet ASTM C-90 specifications.
- It is suggested that a standard electric drill on slow setting is used to drill the hole instead of a hammer drill to avoid breaking out the back of the hole when entering a void or cavity.
- Concrete must be 2000 psi density minimum. Lighter density concrete may not hold anchors.
- Make sure that the supporting surface will safely support the combined load of the equipment and all attached hardware and components.

Figure 1

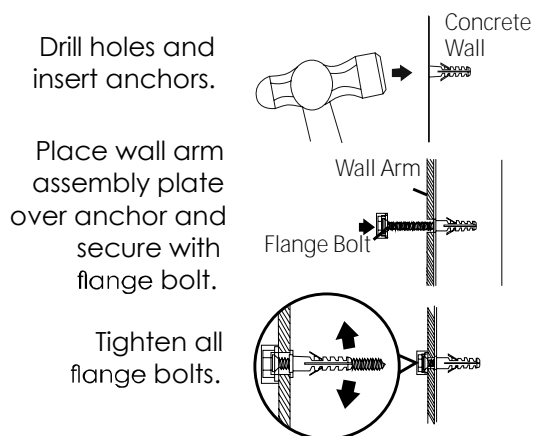

- B-1. Place the Wall Plate on the wall in the desired position for the display.
- B-2. Mark the location of the holes on the wall.
- B-3. Pre-drill holes into concrete using 5/16" drill bits to a depth of 3 1/2". Insert concrete Wall Anchors (W) and tap in with hammer, if necessary (Figures 1 & 2).

Figure 2

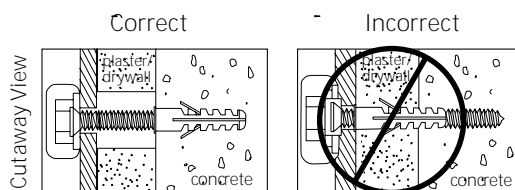

Step 2. Mount the Wall Bracket Assembly

- A-1. Insert 2 Lag Bolts (U) with 2 Lag Bolt Washers (V) into the top holes or Anchors (W) in the wall, and loosely tighten, allowing for clearance for the Wall Plate. (Figure 3)
- A-2. With the orientation marking (Up Arrow) on top, place the Wall Plate on the wall, aligning it with the top Lag Bolts in the wall.
- A-3. Slide the wall plate into position, and insert 2 Lag Bolts (U) with 2 Lag Bolt Washers (V) into the bottom 2 holes or Anchors (W). (Figure 4)
- A-4. Tighten all the bolts.

WARNING: Tighten bolts so that wall plate is firmly attached, but do not over tighten. Over tightening can damage the bolts, greatly reducing their holding strength.

Figure 3

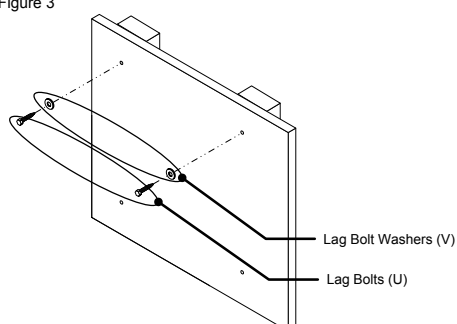
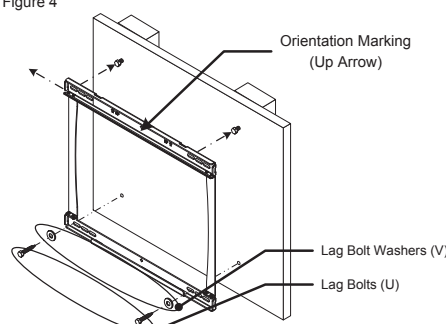

Figure 4



Step 3. Attach the Arm Assembly to the Wall Plate

- A. Lower the Arm Assembly onto the Wall Plate aligning with the bottom rail. (Figure 5)
- B. Align the Arm Assembly with the top rail, and slide the Arm Assembly into position while lowering the Mounting Block Top. (Figure 5)
- C. Slide the Arm Assembly left or right into the desired location, usually centered on the Wall Plate.
- D. Secure the top of the Arm Assembly by tightening the 2 round Head Hex Screws using the S4 Allen Key (AB). (Figure 6)
- E. Secure the bottom of the Arm Assembly by placing the Bottom Mounting Block (AA) in front of the bottom rail on the plate, and tighten the 2 Counter Sunk Hex Screws (Z) using the S4 Allen Key (AB). (Figure 7)
- F. Once the Arm Assembly is secured, the Wall Bracket End Covers can be installed to the top and bottom of the Wall Bracket.

Figure 5

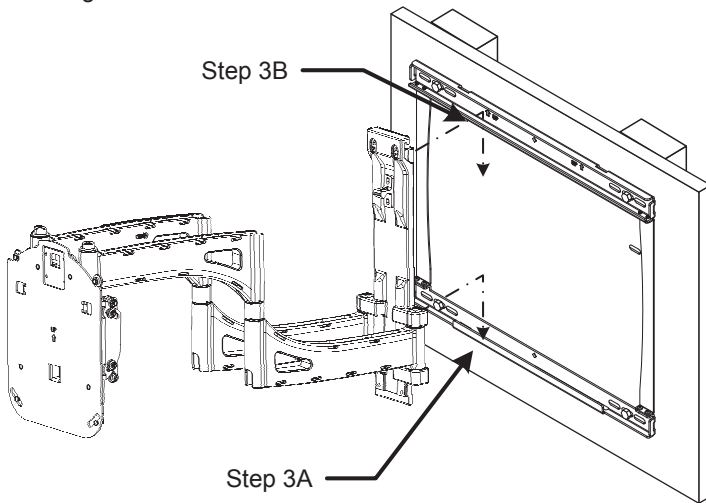

Figure 6

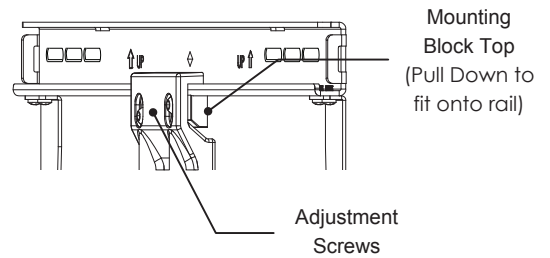
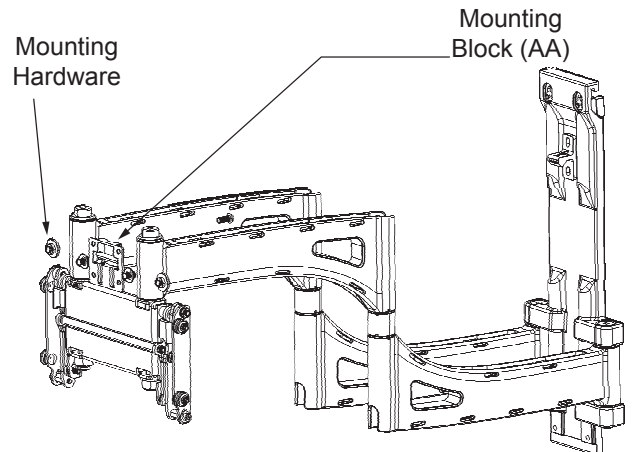

Figure 7



Step 4. Attach TV Plate to Display

- A. With the orientation marking (Up Arrow) towards the top of the TV, place the TV Plate on the back of display aligning the upright bars with the mounting holes on the display. (Figure 8A)
- B. If the holes do not align:
 - B-1. Remove the screws from the vertical bars, and slide the bars until they align with the mounting holes on the display. The vertical bars contain indicators for common patterns that can be used to easily set the spacing of the horizontal bars.

Note: The back of the horizontal bars have markings that follow VESA pattern horizontal increments from 300 to 800. (Figure 8B)

- B-2. Reinsert the screws removed in step 4 B-1, and tighten.

For larger TVs, the SM-RAZOR-ART2-XL contains extension brackets that can be used to extend the vertical bars to fit larger TVs. (Figure 9)

- C. Insert suitable screws (A to P) through the washers (S or T), and the upright bars into the back of the display, and tighten. For displays with recessed mounting holes, spacers (Q or R) can be used between the display and the TV Plate.

Note: The TV Plate should be horizontally centered on the back of the display. If this needs to be adjusted, loosen the screws for the upright bars and align the TV Plate as needed on the back of the display.

Step 5. Attach the Display to the Arm Assembly

- A. Lift the display and place it on the end of the Arm Assembly hooking it to the top of the Arm Plate, and aligning the bottom screws with the slots on the bottom of the Arm Plate. (Figure 10)
- B. Secure the display to the Arm Plate using 2 Washers (X) and Locking Nuts (Y). Tighten the nuts with an S10 Socket Wrench (AD) to ensure the display is securely fastened to the Arm Assembly. (Figure 10)

Figure 8A

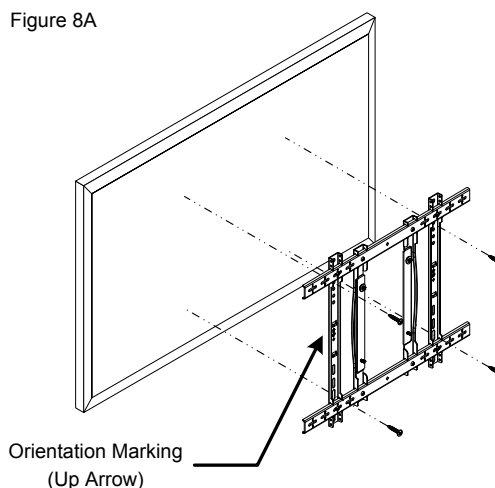

Figure 8B

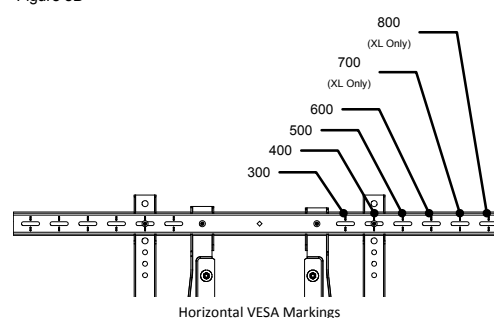

Figure 9

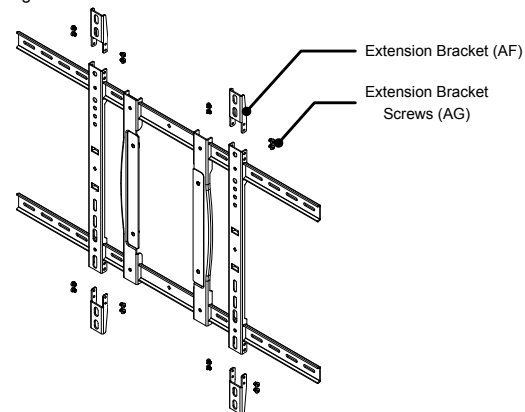
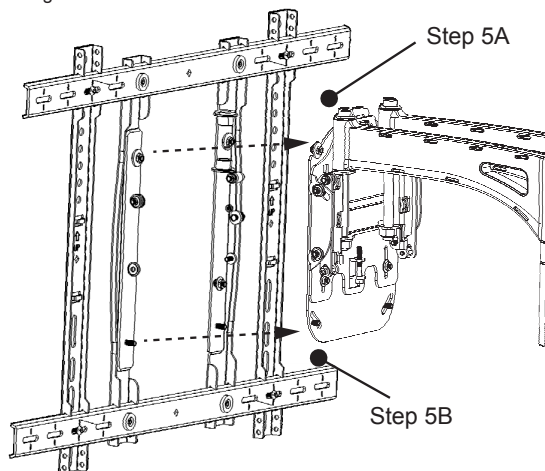

Figure 10



Adjusting Display Position

Step 6. Horizontal Level Adjustments

- A. Loosen the locking nuts at the bottom of the Arm Assembly end plate. (Figure 11)
- B. Place a level on top of the display, and rotate the display until it is horizontally level. (Figure 12)
- C. Tighten the locking nuts at the bottom of the Arm Assembly end plate, and then loosen ¼ turn. This will allow for the display to be positioned with little force.

Figure 11

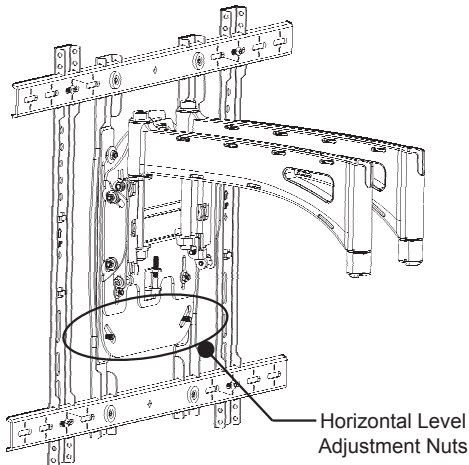
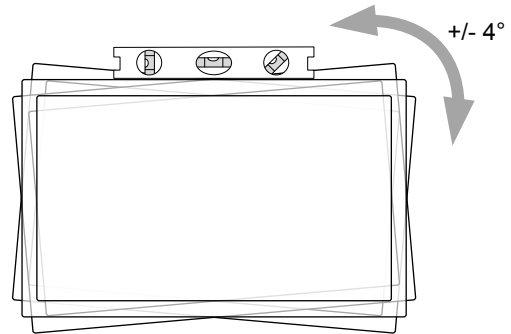

Figure 12



Step 7. Vertical Position Adjustments

The vertical position of the display can be adjusted +/- .5" from the pre-adjusted center by tightening or loosening the Vertical Adjustment Screw located on the Arm Plate.

- A. Extend the Arm to access the Vertical Position Adjustment.
- B. Loosen the 4 Lock Nuts on the rear of the Arm Plate using the S10 Socket Wrench (AD). (Figure 14)
- C. Using the S5 Allen Key (AC), tighten the Adjustment Screw to raise the display, or loosen the screw to lower the display. (Figure 13)
- D. Tighten the 4 Lock Nuts on the rear of the Arm Plate using the S10 Socket Wrench (AD). (Figure 14)
- E. Retract the Arm if necessary.

Figure 13

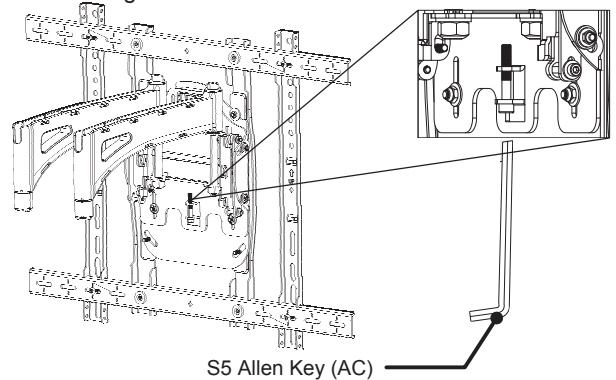
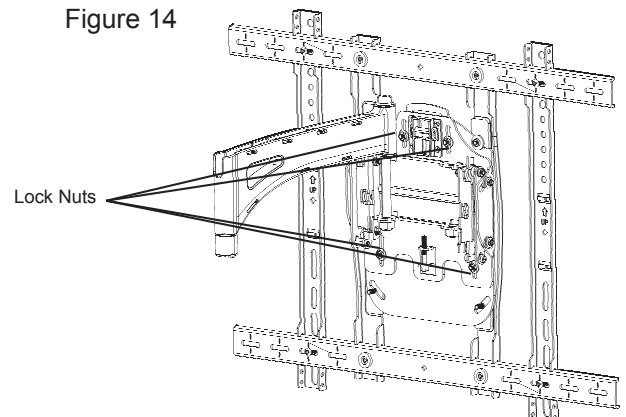

Figure 14



Note: Right Arm Not Shown to Expose Lock Nut Position

Step 8. Adjusting Home Position (Fully Retracted)

The mount includes a Home Position Latch which locks the Arm to the Wall Mount to avoid the display being pushed away from the wall by cabling.

Note: Only the TV Plate side of the latch is pre-installed, the Home Position Latch clip requires installation, and adjustment.

- A. Extend the arm out away from the wall.
- B. Position the Home Position Latch clip over the 2 holes on the vertical bar on the wall side of the Arm Assembly and secure using the included screws. (Figure 15 A)

Note: After tightening, loosen $\frac{1}{4}$ turn to allow for adjusting the position of the clip.

- C. Retract the arm until a “click” sound is heard when the Arm is fully retracted.
- D. If no “click” is heard, note the position of the Latch on the display end of the Arm in relation to the Latching Clip on the wall end of the Arm.
- E. Loosen, but do not remove the screws from the Latching Clip.
- F. Adjust the position of the Clip up or down so that the bottom lines up with the Latch. (Figure 15 B)
- G. Tighten the screws and retract the arm until a “click” sound is heard.

Repeat step 8 A to E until a “click” is heard and the display latches completely to the wall mount.

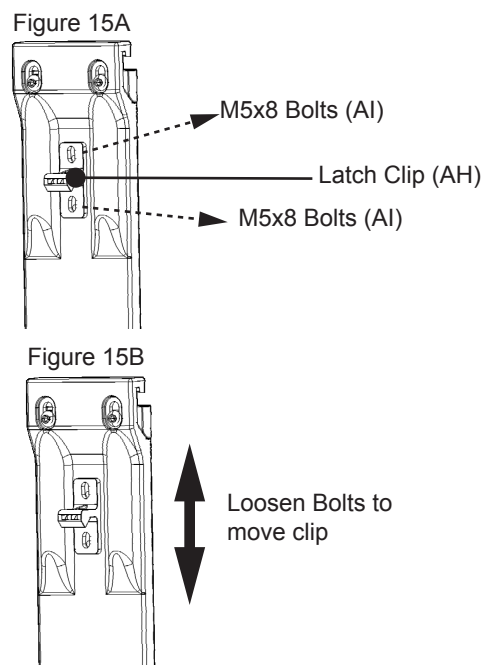

Step 9. Tilt Adjustments

Vertical angle adjusting does not require loosening any bolts or screws. The tilt plate tension has been preadjusted for easy tilt angle changes for most TVs. Heavier TVs may sag due to the extra weight.

If this occurs, simply place the TV at a 0° angle, and tighten the 4 Lock Nuts on each side of the end plate using the S8 Socket Wrench (AE). Once tightened, the TV angle should be adjustable by simply tilting it to the desired angle. (Figure 16)

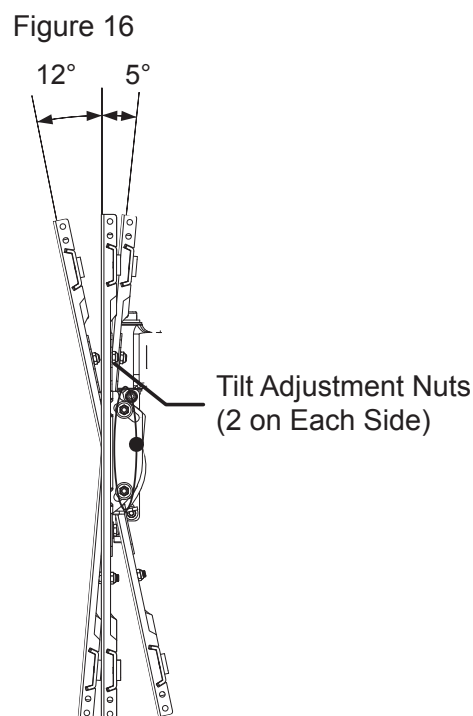

Step 10. Wire Management

Wires can be routed on the top or bottom of the arms, and secured using zip ties. (Figure 17)

Additionally, wires can be zip tied to the clips on the vertical bars of the TV bracket. (Figure 18)

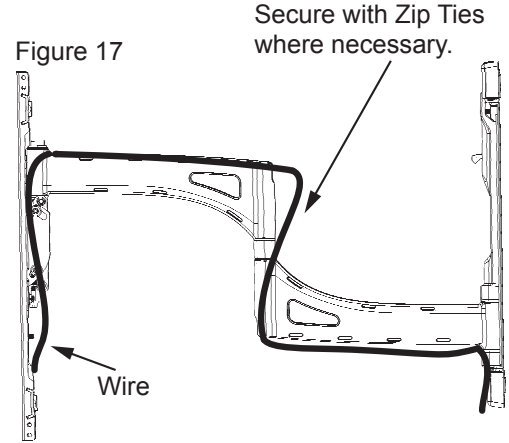
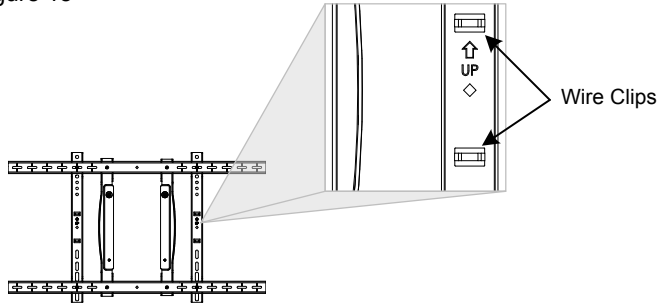
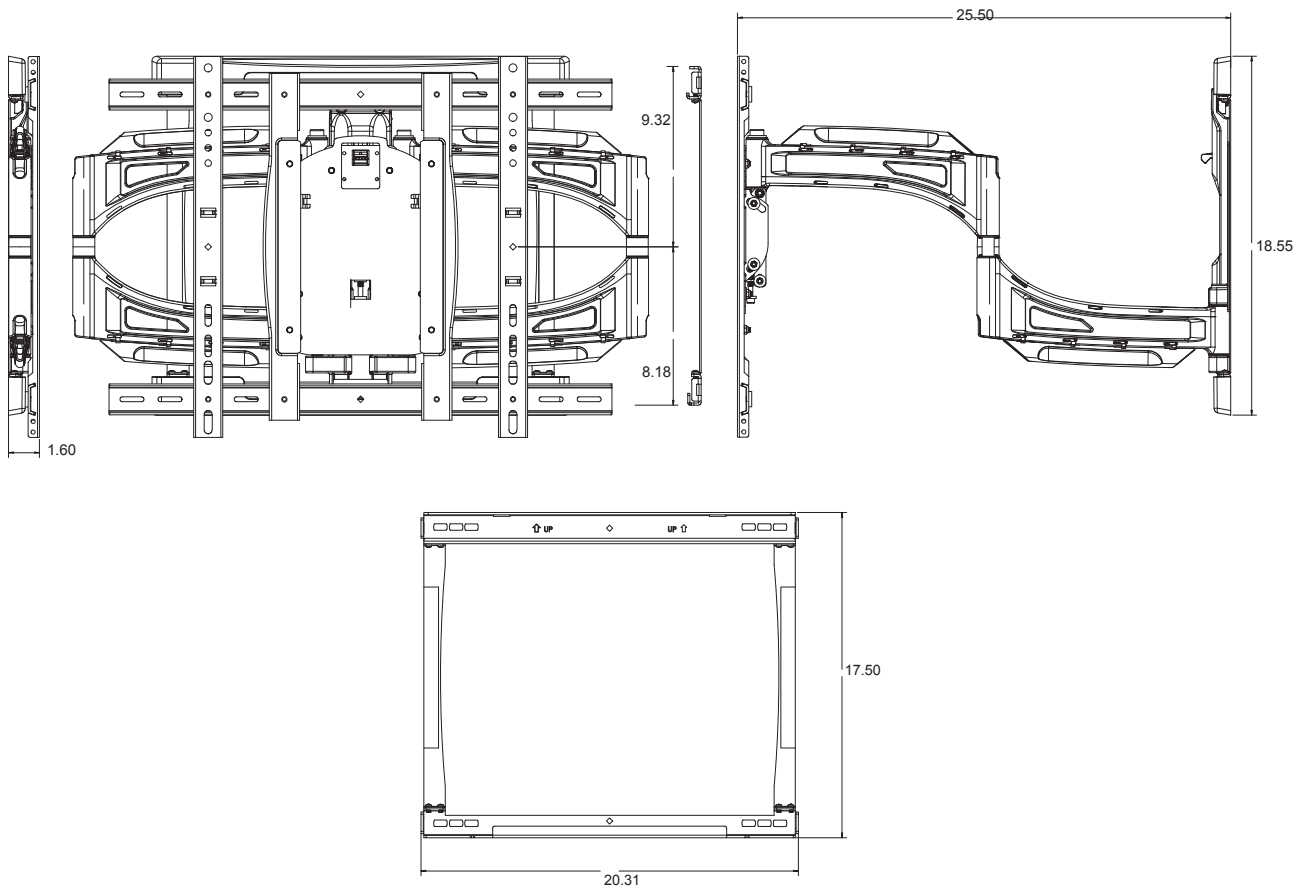

Figure 18



Dimensions





Lifetime Limited Warranty

Strong™ Mounts have a Lifetime Limited Warranty. This warranty includes parts and labor repairs on all components found to be defective in material or workmanship under normal conditions of use. This warranty shall not apply to products which have been abused, modified or disassembled. Products to be repaired under this warranty must be returned to SnapAV or a designated service center with prior notification and an assigned return authorization (RA) number.

Contacting Technical Support

PHONE: (866) 838-5052

EMAIL: TECHSUPPORT@SNAPAV.COM



© 2015 STRONG™
150325-2207